

800 MHz Trunked Radio

Management Briefing Number 2

ONE OF A SERIES OF NOTES ON
TECHNOLOGY FROM ADCOMM

© Copyright Adcomm Engineering 1991

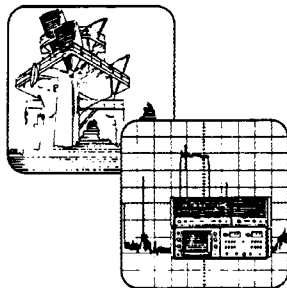

**ADCOMM
ENGINEERING COMPANY**

14631 128th Avenue NE, Kirkland, Washington 98034 (206) 821-8827

This short paper offers discussion on trunked radio systems — it is done as an aid to managers and others with limited technical knowledge of radio communications. The use of some radio jargon and terminology is unavoidable, but terms are explained as needed.

INTRODUCTION

The topic of "trunking radio systems" is a popular one among managers and agencies with a need to provide mobile communications to large, diverse field organizations. Mobile fleet communications were previously the domain of conventional radio systems, but increased crowding of the radio bands has caused the introduction of new trunked or shared-channel techniques.

The "trunking" concept has been used for years by telephone companies. The central idea is that not all users of a network want to be connected at the same time, so the capacity to connect all points simultaneously is not really needed. Figure 1 illustrates the concept. "Trunks" are limited numbers of connecting routes

serving larger numbers of users on a demand-only basis. Telephone companies use such trunks or shared circuits between switching centers. The individual telephone set located in a home or business has its own line from the telephone location to the switching center (i.e., central office) and shares lines between switching centers. For example between Bellevue and Seattle, there are trunks that handle calls between Bellevue telephones and Seattle telephones. These trunks are shared by everyone in Bellevue and Seattle.

The telephone company determines the quantity required based on the average number of people they think may want to call at any given time. The telephone companies have spent many years studying this demand, making a science of it. They want to provide enough trunks to give good service without spending money on unnecessary equipment. Sometimes, on occasions like Mother's Day or Christmas when there is a high calling volume, the trunks will all be busy and a call will be "blocked." Such blockage is inevitable, but properly calculated trunk capacity will make it rare.

The same principles apply to the radio systems we are discussing here.

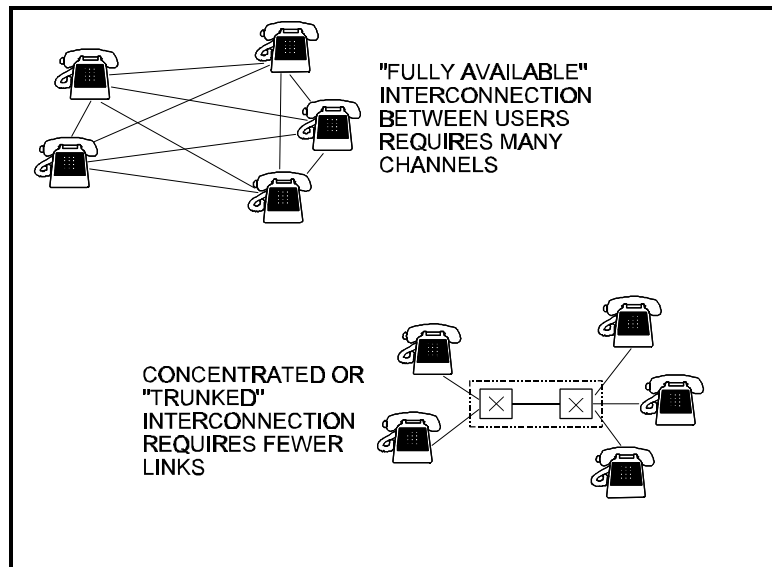

Figure 1

TRUNKING RADIO SYSTEMS

GENERAL CONCEPTS

The concept of trunking for two-way radio was developed in the early 1980s, in the face of increasing congestion of the airwaves. This more-complex technology was made possible by the advent of the microprocessor and the resultant ability to put computers into small, low-power mobile units. The technology appears today in two forms—public cellular telephone and mobile radio. This paper is limited to mobile radio.

A trunking radio system is a single system that can act as though it were several, separate, larger systems. This is its principal characteristic.

A radio system using trunking can be organized to provide groups of users and access arrangements tailored to local needs. Figure 2 is a diagram of what a typical radio user organization could look like. The user groups shown represent different departments within a city but could be company organizations or different companies and cities. The talk groups (TGs in the diagram) operate like the "radio channels" of conventional radio systems. The talk groups can be assigned for various purposes; a water department might have one talk group for the supervisors, one for the instrumentation shop, one for operations, and another for maintenance. A typical large trunking system can accommodate over 4,000 talk groups and as many as 40,000 units!

Figure 3 illustrates the natural ability of such systems to permanently or temporarily assign access to users. Using built-in digital controls at dispatch for example, fire and police units can have talk groups joined (A) for special emergencies, can communicate with other agencies on a different radio system through talk group bridges (B), and individual users can have access to several talk groups (C).

SYSTEM ELEMENTS

The core of a trunking system has two parts.

- ! Base transmitter/receiver units that provide the radio communications.
- ! The central controller that operates the base units and communicates with the mobile or portable units.

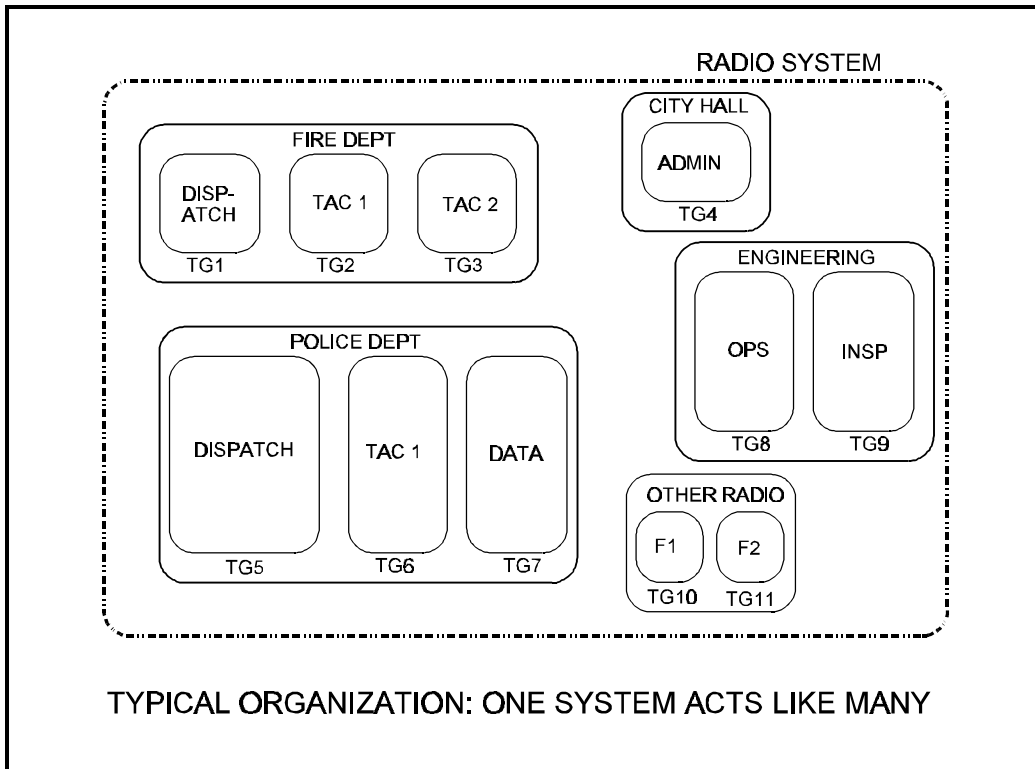

Figure 2

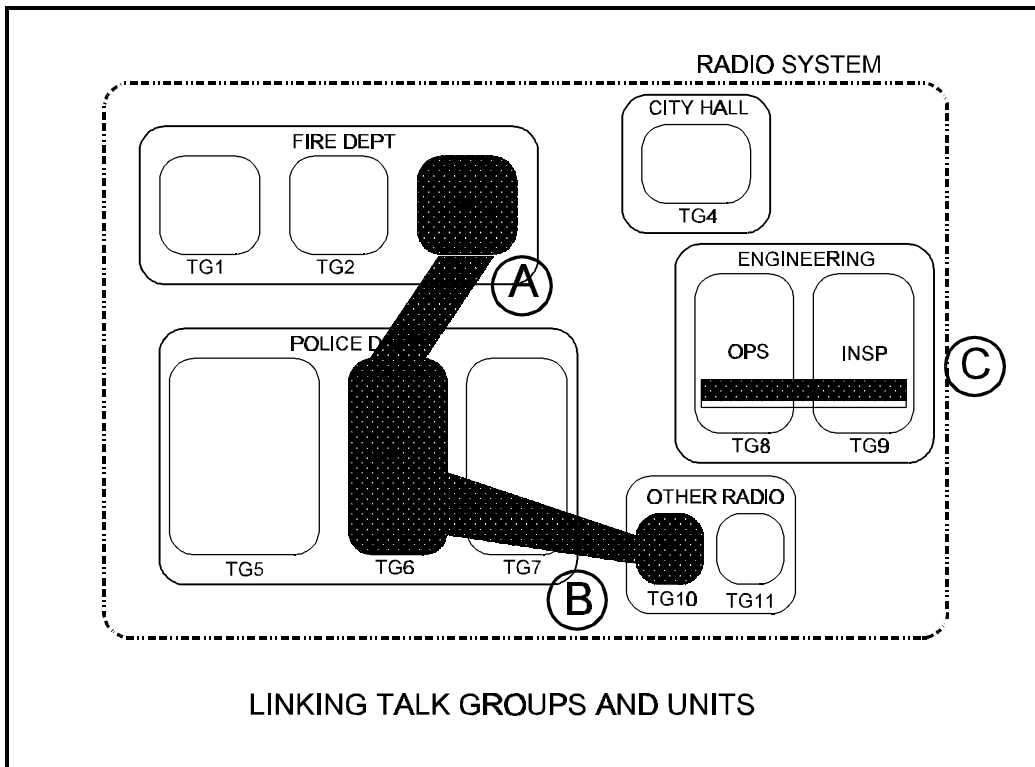

Figure 3

The base transmitter/receiver units are computer-controlled radio signal "repeaters" used by the dispatcher that are also used to boost communications between field units. The central controller is a really a computer system that watches what is going on with the radio channels and units. It knows all of the mobile and portable unit identification codes, the status of equipment, and other operational conditions. The controller, base units, and the other parts of a trunking radio system are seen in Figure 4; all elements have transmitter and receiver capability, while mobile units, portables, and control stations incorporate their own tiny controllers.

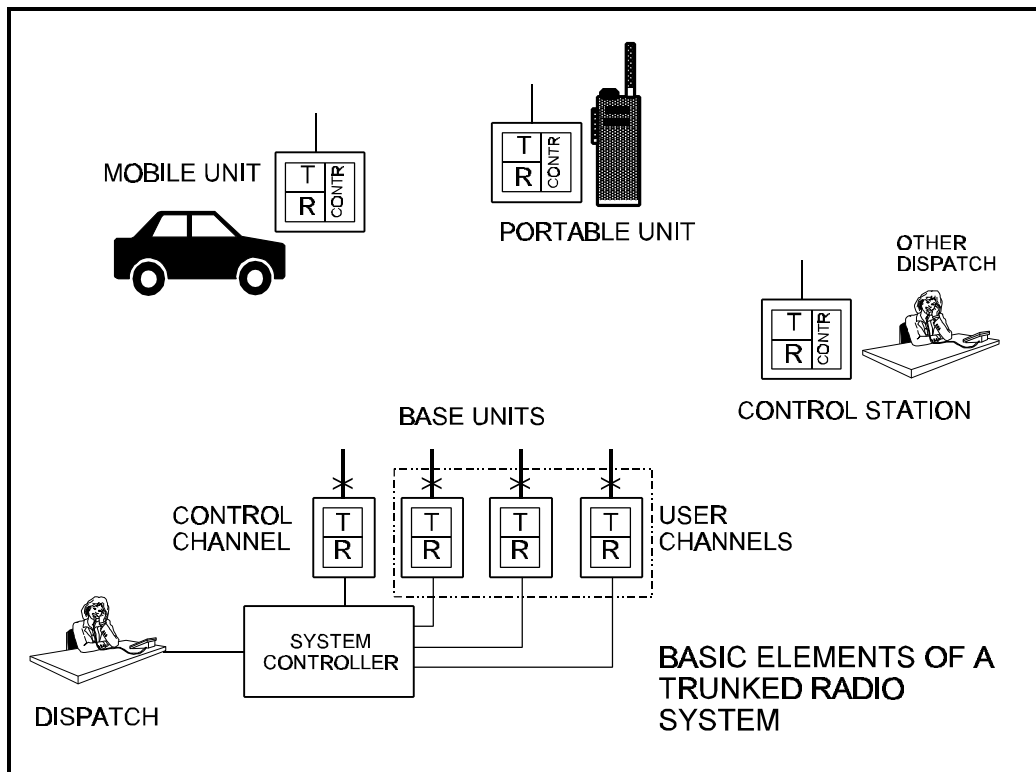

Figure 4

Figure 5 is diagram of an idle system with no one talking. All of the mobile and portable units on the system are listening to the control channel. This control channel tells the mobile units that they are on the right system and carries additional data or commands from the central controller to field units, the central controller is constantly in touch with mobile and portable units. When a mobile unit in Talk Group 1 (TG1) wishes to talk to the other units in Talk Group 1, he presses the button on the microphone. In an instant, a talk request goes to the system on the control link asking for an open channel for the units in Talk Group 1. The controller finds an open channel and then instructs all units of Talk Group 1 to switch to the open radio channel so they can hear the sending unit. This process takes just a few tenths of a second to complete.

When the message is spoken and the microphone button released, the channel is returned to idle status and is ready for use by the next talker. This momentary "talk" link appears in Figure 6.

EXISTING TYPES AND MANUFACTURERS

The crowding that brought on the demand for trunking systems also influenced the radio band chosen by the FCC for the service—800 MHz. In dense areas, where the new trunking technology was needed the most, there was precious little radio spectrum available in the more common 150 MHz (VHF HI) and 450 MHz (UHF) bands, so an alternative was required. The use of trunking and the choice of 800 MHz are as one in the United States; 800-MHz trunking radio has become a single term. In many other parts of the world, trunking radio systems (cellular telephone is an example) operate in the 450 MHz bands.

Today there are three major vendors of trunking radio systems in the United States, with many systems in use. They are Ericsson-GE, Motorola, and E.F. Johnson. The Ericsson-GE and Motorola systems operate similarly, while the E.F. Johnson system takes a slightly different technical approach, though all three make use of trunking concepts. Unfortunately, none of the three manufacturers build equipment that is compatible with that of another manufacturer. At this point, only Motorola and Ericsson-GE offer equipment to their own standards. E.F. Johnson has licensed some other radio manufacturers to build equipment compatible with their system, giving users some choice.

PRO AND CON ON 800 MHz TRUNKING

PRO: 800 MHz TRUNKING

9 Pro — Capacity

The efficiency of trunking makes it possible to place a large number of independent users on a limited number of radio channels. The channels are in a new part of the radio spectrum not yet crowded and are carefully administered regionally by users. The capacity of the system allows multiagency use, meaning the costs can be shared.

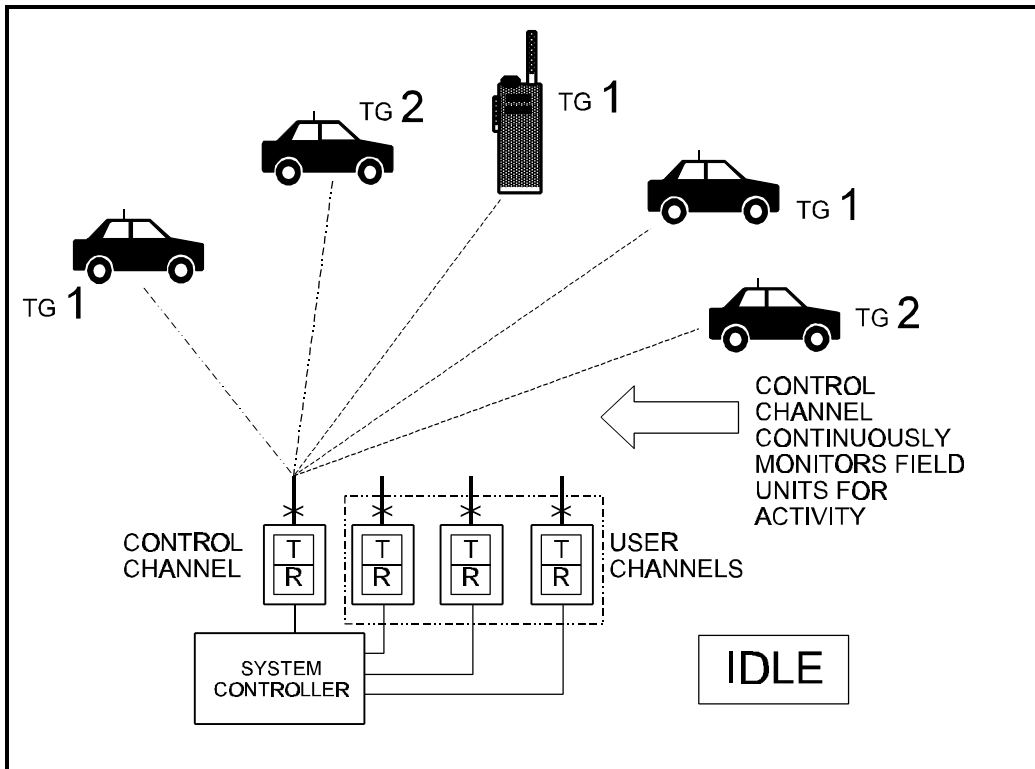

Figure 5

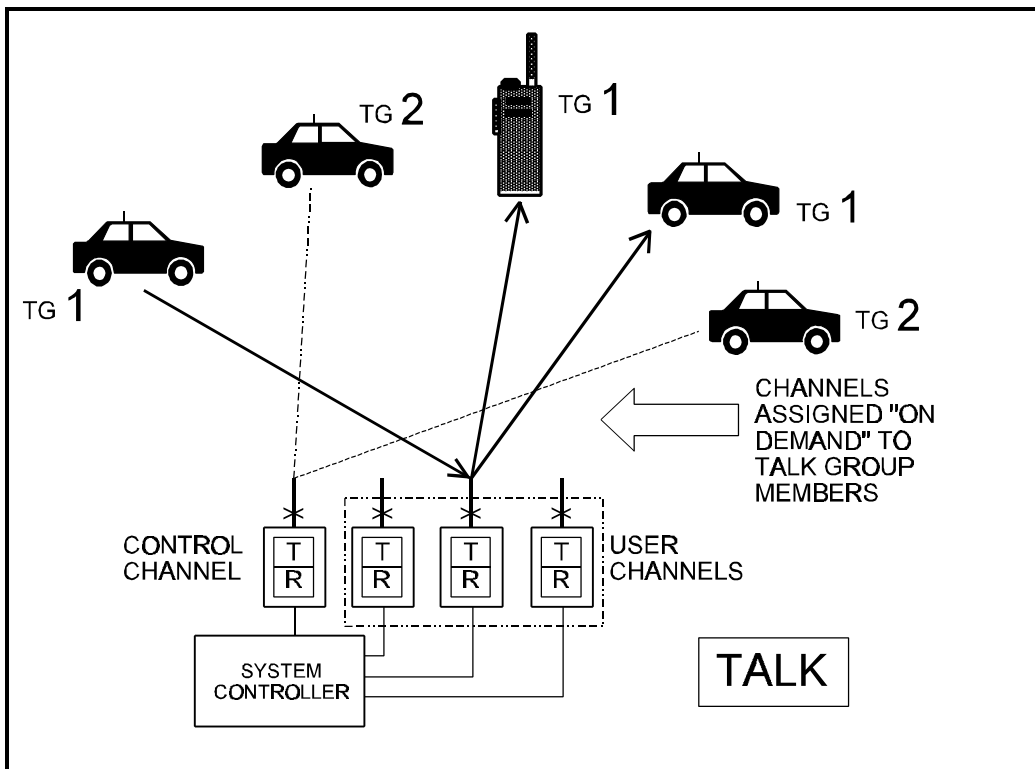

Figure 6

9 Pro — Advanced Features

The computers in the radios and the central controller allow some advanced features to be designed into a trunking system. The system uses the unique identification number assigned to each unit to implement many of the features. Some of the advanced features are:

- Priority Queuing

This allows units assigned a higher priority to be granted an available channel before other units. For example, police and fire units may be given a higher priority than a street cleaning unit. If the system gets very busy and some blockage starts to occur, the highest priority units will then be least affected.

- Selective Signaling

Since each unit has a unique identity, it can be individually selected from the dispatch console or from specially-equipped mobile and portable units. Supervisors are often equipped to selectively signal individual units in the system.

- Automatic Unit Identification

The units send their identification (ID) number each time they transmit, allowing the dispatcher to know what unit is calling. The system can then use this information to log the time and duration of calls from each unit. This can be useful in reconstructing events surrounding an emergency incident or to reduce the amount of "playing around" on the radio.

- Emergency Alert

The mobile and portable units can be programmed to send an inaudible alarm code when an "emergency button" is pressed. The dispatcher is alerted to the code and receives the unit identification.

- Busy Call Back

If all of the channels should be busy when a transmission request (a push of the microphone button) is made, the central controller will place the unit's identification on a list. When a channel is available, the controller will beep the unit back.

- Talk Group Merging

Talk groups can be merged together for an emergency or special event. For example, police department channels and a street sanding channel could be merged together so that the two groups could communicate during a large snowstorm. This can be done from the dispatch center.

- Selective Inhibit

An individual radio can be inhibited from listening or transmitting on the system. Since each individual radio ID must be programmed into the system, the system will not let the

unit onto the system if the ID is not on the list. This allows the system manager to disable stolen or lost radios.

9 Pro — Privacy

It can be hard to follow conversations with a scanner in larger trunking systems, as the exchanges between parties may hop from channel to channel. It is not as secure as encryption, and channel re-assignment makes eavesdropping less attractive.

9 Pro — Management

The use of a digital computer as a trunking master controller makes it possible to provide management information and user control not available in most other types of radio systems. Benefits include reports on usage levels, channel crowding, dispatch activity and unit status, and trimming and grouping flexibility.

CON: 800 MHz TRUNKING

: Con — Coverage

Radio spectrum crowding is forcing new systems higher and higher in frequency, with some loss in the coverage area of individual transmitters and receivers. Usually this calls for more base unit sites to be constructed and may still leave "holes." See Figure 7 for a general view of the spectrum for mobile radio. Note that, as a rule, the cost goes up while range goes down as we move higher in the spectrum (higher in frequency).

: Con — Cost

Increased cost, both initial and recurring, is a natural result of the complexity of 800-MHz trunking radio and the reduced range. The increase is less a factor if the capacity of the system is well used.

: Con — Compatibility

As the technology has developed, vendor-specific offerings have been the rule. Generally, a user of Motorola equipment will not be able to communicate within an Ericsson-GE system or an E.F. Johnson system and vice-versa. Talk group "portals" must be connected to different radio systems to permit interworking.

: Con — Complexity

Trunking systems are more complex and so more difficult to install and maintain than a conventional radio system. This means higher maintenance costs and a higher startup cost. The flexibility of the system can mean administrative burden, all of the unit identifications and talk group assignments must be programmed into the system and kept up to date, for instance. This can be a

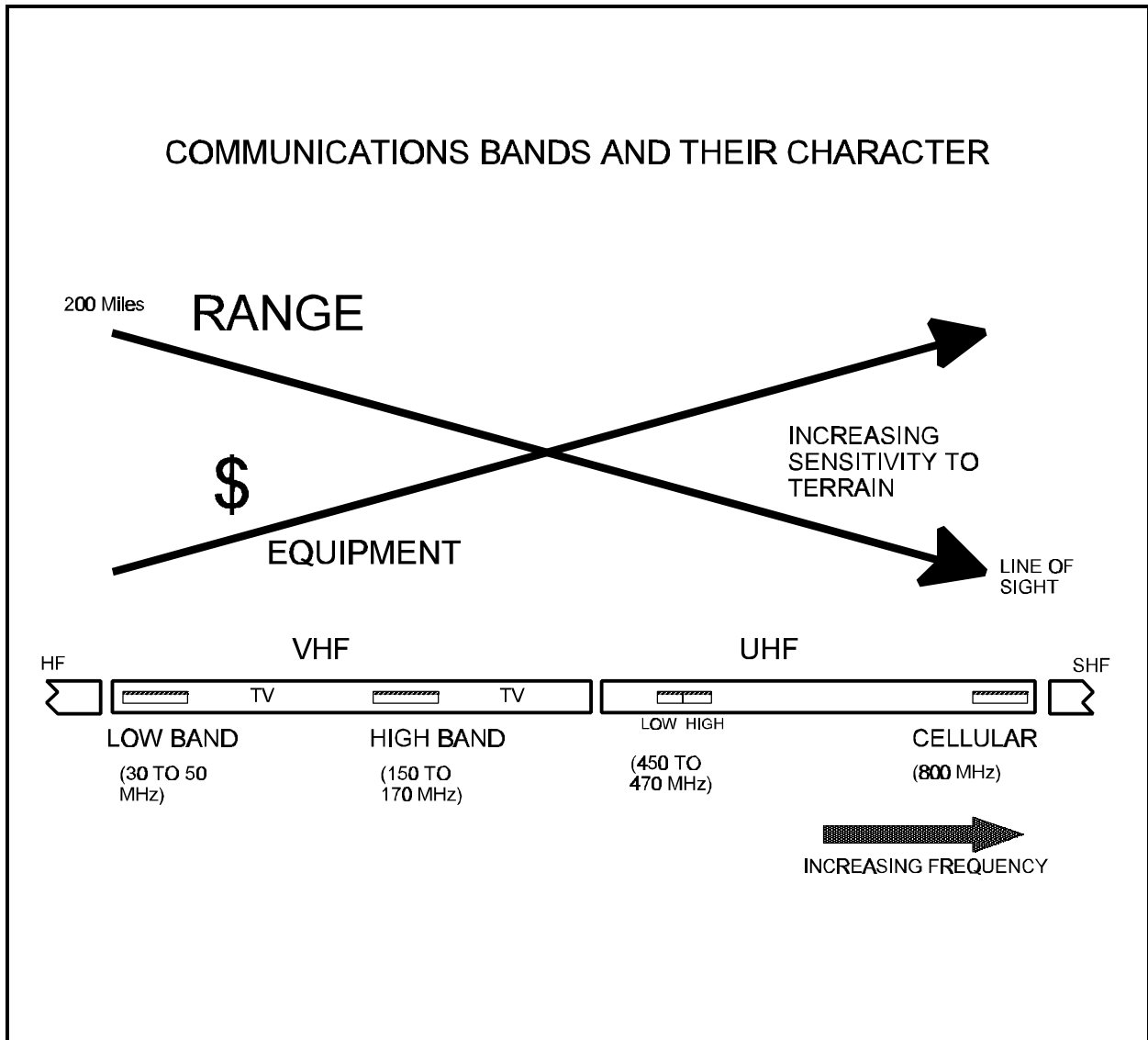

Figure 7

big data management job. Installing and operating a trunking system is much like installing and operating a computer system.

SUMMARY

An application of modern technology to the problem of radio channel congestion and management is 800-MHz trunking radio. It uses digital control and computer techniques to *expand the number of users that can be accommodated by a single radio system*, providing higher capacity and improved flexibility.

With the benefits come the initial and on-going costs associated with the complex technology.